

NT12-26 DEEP CYCLE AGM BATTERY

Characteristics

Nominal Voltage		12V
Nominal Capacity (10 hours rate)		26Ah
Capacity 25°C(77°F)	10 hours rate (2.6A)	26Ah
	3 hours rate (6.5A)	19.5Ah
	1 hour rate (14.3A)	14.3Ah
Internal Resistance	Full Charged Battery 25°C (77°F)	≈9mΩ
Cyclic Life	50%(C ₁₀) Depth of discharge	900 Times
Float Life	25°C(77°F) Float charge at 13.8V	8 Years
Maximum Discharge Current		260A(5s)
Capacity affected by Temperature (10 hour)	40°C (104°F)	102%
	25°C (77°F)	100%
	0°C (32°F)	85%
	-15°C (5°F)	65%
Self-Discharge 25°C(77°F)	Capacity after 3 months storage	90%
	Capacity after 6 months storage	80%
	Capacity after 12 months storage	62%
Charge (Constant Voltage) 25°C (77°F)	Cycle	Initial Charging Current Less than 7.8A, Voltage 14.58-15V
	Float	Voltage 13.5-13.8V
Operating Temp. Range	discharge	-20°C~60°C
	Charge	0°C~50°C
	Storage	-20°C~60°C

Product Image



Packing

Battery (L×W×H)	mm±1	167×175×125
	inch	6.58×6.89×4.93
Box (L×W×H)	mm±2	190×177×142
	inch	7.48×6.97×5.60
Quantity Per Box		1 PCS
Net weight Per Cell		7.5 Kg±70g
Net weight Per Box		7.5 Kg
Gross Weight		7.8 Kg

Discharge Curve

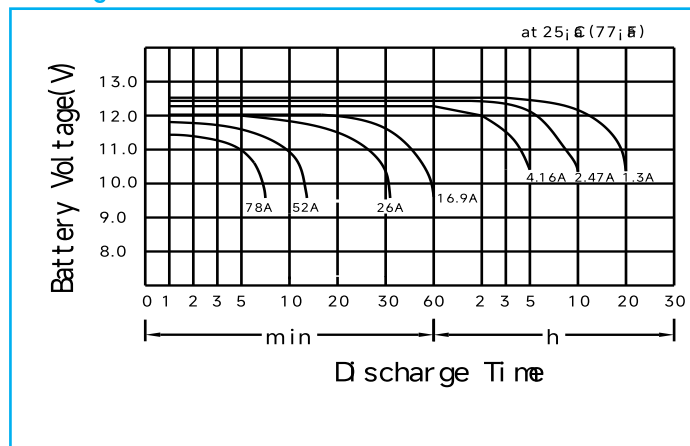

Product Dimensions

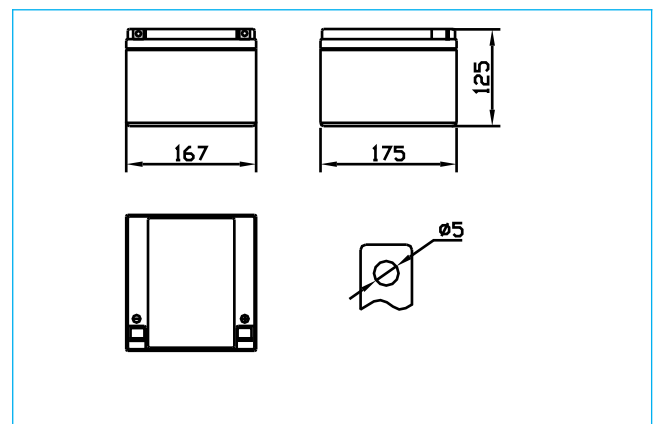

Battery Construction

Component	Positive plate	Negative plate	Container	Safety valve	Terminal	Separator		Electrolyte
Raw Material	Lead	Lead	ABS, UL94 HB-V0	Rubber	Copper/Pb	Absorptive	Glass Mat	Sulfuric acid

	dioxide					(AGM)	
--	---------	--	--	--	--	-------	--

Discharge Characteristics

Voltage	Run Time (Constant Current and Power 25°C 77°F)											
	3 min	5 min	15 min	30 min	45 min	1h	2h	3h	5h	8h	10h	20h
9.6 V	1123	993	574	349	243	195	105	76.2	51.8	34.0	28.4	15.5
10.2V	1012	908	518	320	237	192	103	75.4	51.2	34.0	28.4	15.5
10.5V	843	795	489	301	234	189	102	74.3	51.2	33.6	28.1	15.2
10.8V	785	710	460	260	231	185	98.8	72.3	50.7	33.6	27.5	14.8

Neata Battery Manufacture Co., Ltd.

Discharge Characteristics Curve

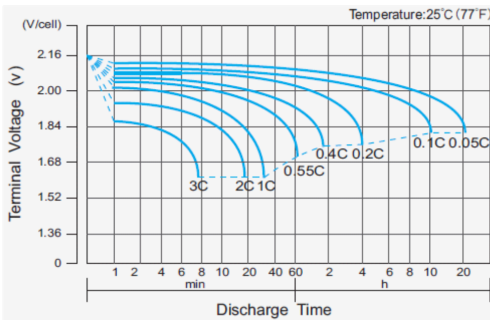

Charging Characteristics

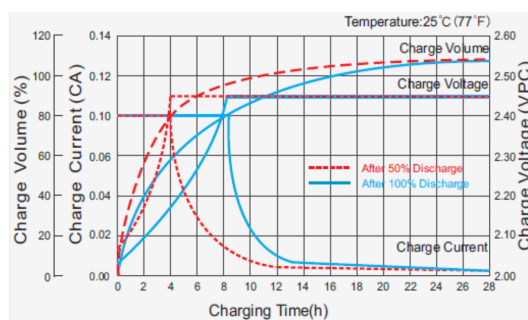

Cycle Life vs. Depth of Discharge (25°C)

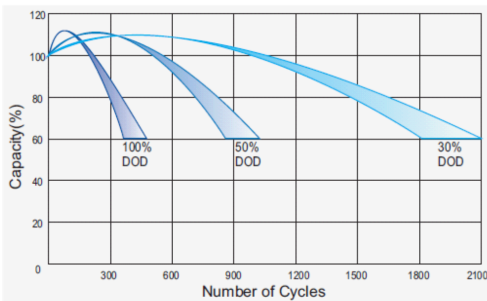

Temperature Effects on Capacity

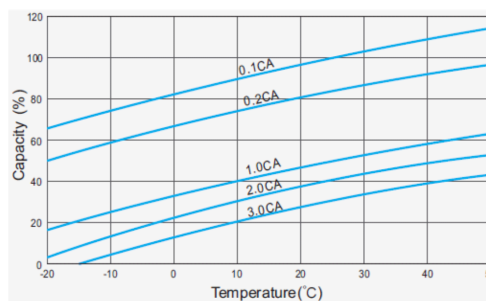

Effect of Temperature on Long Term Life

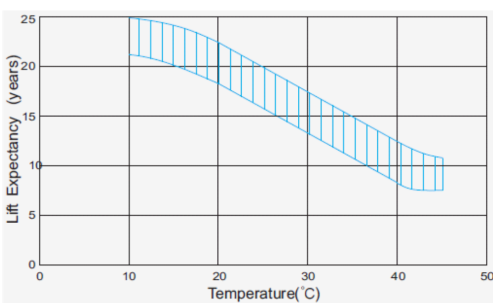

Storage Characteristics

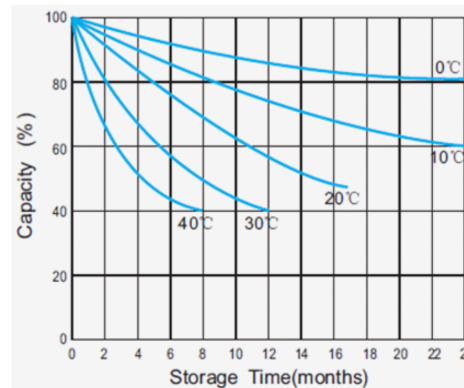

Neata Battery Manufacture Co., Ltd.

Address: West Zone Industrial park, Xiaolan, Zhongshan, Guangdong, China

ISO9001 STANDARD CERTIFY

